



Instructions for the following series products:

Boatswain's Chairs, Work Seats, and Seat Slings
(See back page for specific model numbers.)

**USER INSTRUCTION MANUAL FOR
BOATSWAIN'S CHAIRS, WORK SEATS, AND SEAT SLINGS**

This manual is intended to meet the Manufacturer's Instructions as required by ANSI Z359.1 and should be used as part of an employee training program as required by OSHA.

Figure 1 - Personnel Riding Systems

**Boatswain's Chair
(Large Seat Board)**



**1001134
shown**

**Work Seat
(Small Seat Board)**



**1001004
shown**

**Work Seat with
Seat Sling**



**1001044
shown**

Seat Sling



**1001090
shown**

DESCRIPTIONS

DBI/SALA boatswain's chairs, work seats, and seat slings are available in various styles and configurations. Following are descriptions of typical systems. See Figure 1.

Boatswain's Chair:

- 1001140:** Seat board: 12 in. x 24 in. x 1 in.
- 1001134:** Seat board: 12 in. x 24 in. x 1 in., tongue buckle belt with 3 in. pad, and back D-ring
- 1001170:** Seat board: 12 in. x 24 in. x 1 in., cushion
- 1001180:** Seat board: 12 in. x 24 in. x 1 in., side snaps for tools
- 1001190:** Seat board: 12 in. x 24 in. x 1 in., cushion, side snaps for tools
- 1001378:** Seat board: 18 in. x 15 in. x 1 in., full chair, 420 lbs capacity

Work Seats:

- 1001150:** Seat board: 8 in. x 18 in. x 3/4 in.
- 1001004:** Seat board: 8 in. x 18 in. x 3/4 in.; tongue buckle body belt; back D-ring; adjustable leg and shoulder straps
- 1001044:** Seat sling: 3 in. wide web; belt with suspension D-rings

Seat Slings:

- 1001120:** Seat sling: 4 in. wide; belt attachment loops and suspension D-rings
- 1001090:** Seat sling: 8 in. wide; belt attachment loops and suspension D-rings

WARNING: This product is part of a suspended support system. The user must follow the manufacturer's instructions for each component of the system. These instructions must be provided to the user of this equipment. The user must read and understand these instructions before using this equipment. Manufacturer's instructions must be followed for proper use and maintenance of this equipment. Alterations or misuse of this equipment, or failure to follow instructions, may result in serious injury or death.

IMPORTANT: If you have questions on the use, care, or suitability of this equipment for your application, contact DBI/SALA.

IMPORTANT: Record the product identification information from the ID label in the "Inspection and Maintenance Log".

Figure 2 - Boatswain's Chair, Work Seat, and Seat Sling

Boatswain's Chair

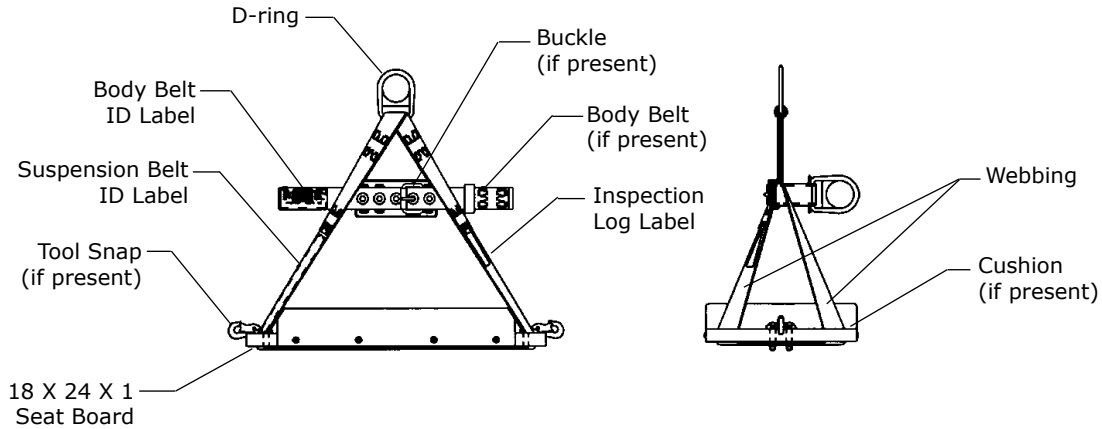

Work Seat

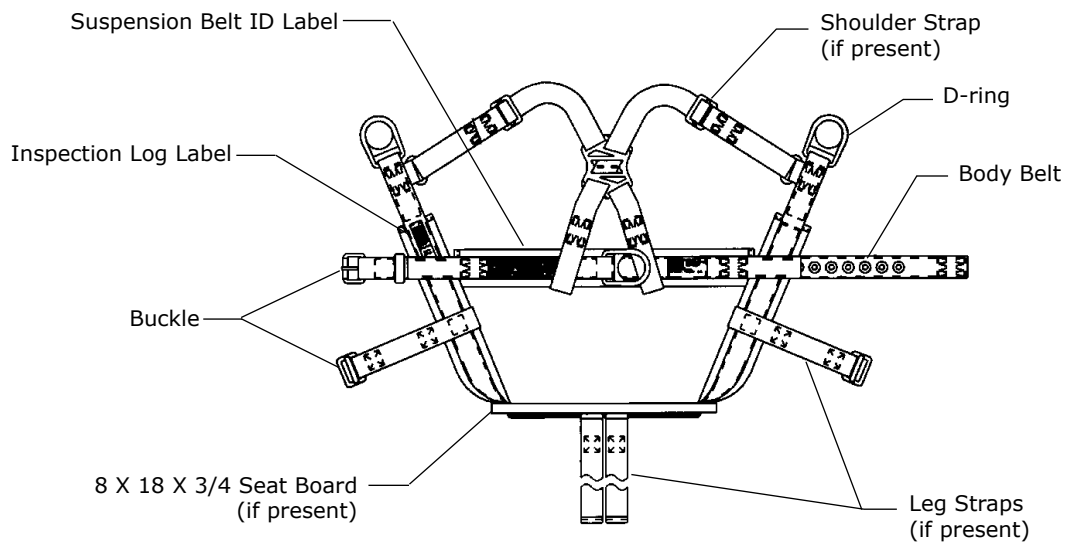

Seat Sling

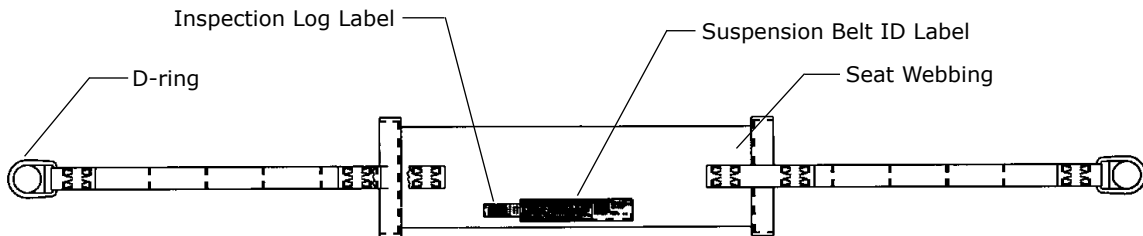

DEFINITIONS

ANCHORAGE: A properly selected means, such as a structural beam or member, to which the system is anchored.

ANCHORAGE CONNECTOR: A component, such as a connector or subsystem, specifically intended for coupling the system to an anchorage.

CONNECTOR: A component or element used to couple parts of the system together, such as a lifeline to an anchorage using a carabiner as an anchorage connector.

COMPONENT: An assembly of parts which cannot be disassembled without mutilating, or without the use of special tools, intended to perform one function in the system. Examples of components include a full body harness, lanyard, and connector.

WARNING: This product is part of a personal restraint, work positioning, suspension, or rescue system. These instructions must be provided to the user and rescuer (see section 8.0 Terminology). The user must read and understand these instructions or have them explained to them before using this equipment. The user must read and follow the manufacturer's instructions for each component or part of the complete system. Manufacturer's instructions must be followed for proper use and maintenance of this product. Alterations or misuse of this product or failure to follow instructions may result in serious injury or death.

IMPORTANT: If you have questions on the use, care, or suitability for use of this safety equipment, contact DBI-SALA.

1.0 APPLICATIONS

1.1 PURPOSE: Boatswain's chairs, work seats, and seat slings are intended to be used as part of a personnel riding system. Applications include: Inspection work, window washing, painting, and maintenance. Some work seats can be used in work positioning applications.

- A. PERSONNEL RIDING:** Boatswain's chairs, work seats, and seat slings are used in conjunction with a complete backup fall arrest system to support, suspend, position, or transport the worker. See Figure 3.
- B. FALL ARREST (BACKUP):** A separate fall arrest system is required by OSHA to be used with boatswain's chairs, work seats, or slings. This typically consists of a full body harness in conjunction with a rope grab and lifeline.
- C. WORK POSITIONING:** Some work seats and tree trimmer's belts can be used to help position and support the user at a work position.

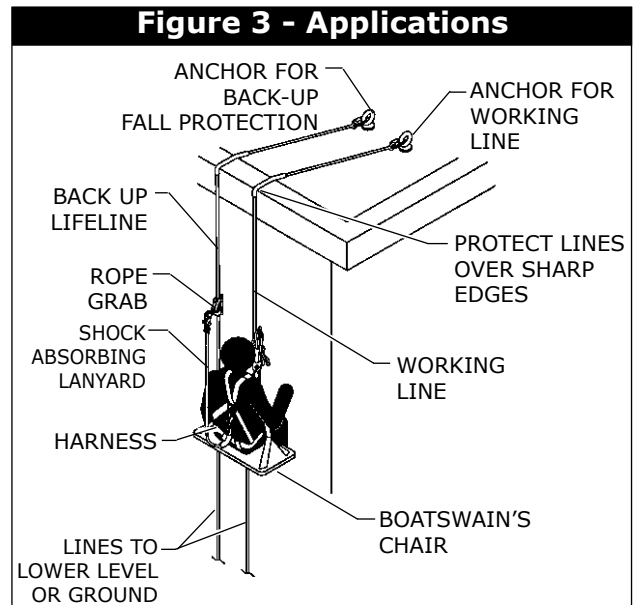

1.2 LIMITATIONS: Consider the following application limitations before using this equipment:

- A. CAPACITY:** This equipment is designed for use by persons with a combined weight (person, clothing, tools, etc.) of no more than 310 lbs (no more than 420 lbs for 1001378).
- B. ENVIRONMENTAL HAZARDS:** Use of this equipment in areas where environmental hazards exist may require additional precautions to reduce the possibility of injury to the user or damage to the equipment. Hazards may include, but are not limited to; high heat, caustic chemicals, corrosive environments, high voltage power lines, explosive or toxic gases, moving machinery, or sharp edges.
- C. SWING IMPACTS:** Swing impacts may occur when a suspended worker uses some means to move their seat or sling from directly beneath their anchor point. The force of striking an object in a swing may cause serious injury or death. Minimize swing impacts by working as close to directly below the anchorage point as possible. Do not permit a swing if injury could occur. Swinging will significantly increase the clearance required when a self retracting lifeline or other variable length connecting subsystem is used for the backup fall arrest system.
- D. FREE FALL:** Boatswain's chairs, work seats, and seat slings are not to be used to arrest a free fall.
- E. TRAINING:** This equipment is intended to be used by persons trained in its correct application and use.

1.3 APPLICABLE STANDARDS: A separate fall arrest system is required by OSHA (see OSHA1910.28 and OSHA1926.451) to be used with boatswain's chairs work seats, or seat slings. This typically consists of a full body harness in conjunction with a rope grab and lifeline or self retracting life line attached to the back D-ring. Refer to national standards, including ANSI Z359.1, ANSI A10.14, and local, state, and federal (OSHA 1910.66, appendix D, 1926.500, 1926.451) requirements for more information on personal fall arrest systems and associated components.

2.0 SYSTEM REQUIREMENTS

2.1 COMPATIBILITY OF CONNECTORS: DBI/SALA equipment is designed for use with DBI/SALA approved components and subsystems only. Substitutions or replacements made with non-approved components or subsystems may jeopardize compatibility of equipment and may effect the safety and reliability of the complete system.

COMPATIBILITY: Connectors are considered to be compatible with connecting elements when they have been designed to work together in such a way that their sizes and shapes do not cause their gate mechanisms to inadvertently open regardless of how they become oriented. Contact DBI/SALA if you have any questions about compatibility. Connectors (hooks, carabiners, and D-rings) must be capable of supporting at least 5,000 lbs. (22kN). Connectors must be compatible with the anchorage or other system components. Do not use equipment that is not compatible. Non-compatible connectors may unintentionally disengage. See Figure 4. Connectors must be compatible in size, shape, and strength. Self locking snap hooks and carabiners are required by ANSI Z359.1 and OSHA.

2.2 MAKING CONNECTIONS: Only use self-locking snap hooks and carabiners with this equipment. Only use connectors that are suitable to each application. Ensure all connections are compatible in size, shape and strength. Do not use equipment that is not compatible. Ensure all connectors are fully closed and locked.

DBI/SALA connectors (snap hooks and carabiners) are designed to be used only as specified in each product's user's instructions. See Figure 5 for inappropriate connections. DBI/SALA snap hooks and carabiners should not be connected:

- A. To a D-ring to which another connector is attached.
- B. In a manner that would result in a load on the gate.

NOTE: Large throat opening snap hooks should not be connected to standard size D-rings or similar objects which will result in a load on the gate if the hook or D-ring twists or rotates. Large throat snap hooks are designed for use on fixed structural elements such as rebar or cross members that are not shaped in a way that can capture the gate of the hook.

- C. In a false engagement, where features that protrude from the snap hook or carabiner catch on the anchor and without visual confirmation seems to be fully engaged to the anchor point.
- D. To each other.
- E. Directly to webbing or rope lanyard or tie-back (unless the manufacturer's instructions for both the lanyard and connector specifically allows such a connection).
- F. To any object which is shaped or dimensioned such that the snap hook or carabiner will not close and lock, or that roll-out could occur.
- G. In a manner that does not allow the connector to align properly while under load.

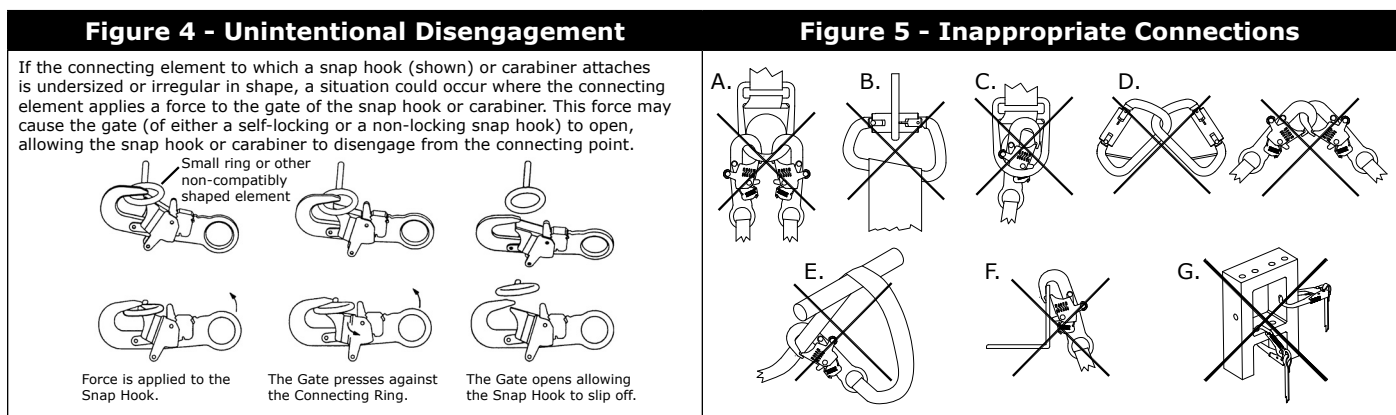

2.3 ANCHORAGE STRENGTH: The anchorage strength required is dependent upon the application:

- A. **PERSONNEL RIDING:** The structure (mounting surface) selected for personnel riding applications must sustain a static load of at least 2,500 lbs. applied in the directions permitted by the personnel riding system when in use.
- B. **FALL ARREST (BACKUP SYSTEM):** Anchorages used for personal fall arrest systems must be capable of sustaining static loads in the directions permitted by the personal fall arrest system of at least: 3,600

lbs. with certification of a qualified person; or 5,000 lbs. without certification. See ANSI Z359.1 for certification definition. When more than one personal fall arrest system is attached to an anchorage, the strengths stated above must be met at each anchorage location independently.

FROM OSHA 1926.500 AND 1910.66: Anchorages used for attachment of personal fall arrest systems shall be independent of any anchorage being used to support or suspend platforms, and capable of supporting at least 5,000 lbs. per user attached, or be designed, installed, and used as part of a complete personal fall arrest systems which maintains a safety factor of at least two, and is under the supervision of a qualified person.

- C. WORK POSITIONING:** The structure to which the work positioning system is attached must sustain static loads applied in the directions permitted by the work positioning system of at least 3,000 lbs., or twice the potential impact load, whichever is greater. See OSHA 1926.502. When more than one work positioning system is attached to an anchorage, the strengths stated above must be multiplied by the number of work positioning systems attached to the anchorage.

3.0 OPERATION AND USE

WARNING: Do not alter or intentionally misuse this equipment. Consult DBI/SALA when using this equipment in combination with components or subsystems other than those described in this manual. Some subsystem and component combinations may interfere with the operation of this equipment. Use caution when using this equipment around moving machinery, electrical hazards, chemical hazards, and sharp edges.

WARNING: Consult your doctor if there is reason to doubt your fitness to safely absorb the shock from a fall arrest. Age and fitness seriously affect a worker's ability to withstand falls. Pregnant women or minors must not use DBI/SALA boatswain's chairs, work seats, seat slings, or fall arrest back up systems.

- 3.1 BEFORE EACH USE** of this equipment, carefully inspect it according to steps listed in section 5.0 of this manual.
- 3.2 PLAN** your fall arrest system before using this equipment. Consider all factors that will affect your safety during use of this equipment. Consider the following points when planning your system:
 - A. ANCHORAGE:** Select a rigid anchor point that is capable of sustaining the loads specified in section 2.3. For fall arrest applications, select anchorage locations that will minimize free fall and swing fall hazards.
 - B. FALL CLEARANCE (BACKUP FALL ARREST):** Ensure sufficient clearance exists in your fall path to prevent striking an object during a fall. The clearance required is dependent upon the subsystem (rope grab and lanyard, rope grab and carabiner) and lifeline properties.
 - C. SHARP EDGES:** Avoid working where your chair's support system, lifeline subsystem, or other system components will be in contact with, or abrade against, unprotected sharp edges. If working with this equipment around sharp edges is unavoidable, provide protection by using a heavy pad over the exposed sharp edge.
 - D. RESCUE:** The employer must have a rescue plan and the ability to implement it.
 - E. AFTER A FALL:** Components which have been subjected to fall arrest forces must be removed from service and destroyed.
 - F. GENERAL USE CONSIDERATIONS:** Avoid working where your lifeline may cross or tangle with that of another worker. Do not allow your lifeline to pass under your arms or between your feet.
- 3.3 DONNING AND USE:** Sit in the chair or sling with the support webbing in front of your body. If belts are present, make sure the belts pass through the appropriate loops in the webbing to assure the user is tied into the system correctly. Refer to Figure 1 for examples of properly donned equipment. Make sure belts are snug and buckles are fully engaged (see Figure 6). If leg straps are present, secure the straps around each leg and adjust to a snug fit. For seat slings, position the seat webbing under the buttocks for maximum support and comfort. Attach backup fall protection system per the manufacturer's instructions for that system.
- 3.4 AFTER USE** of this equipment, clean and store according to section 6.0 of this manual.

Figure 6 - Buckle Connections



Parachute Buckle: Pass webbing under buckle and over roller and down between roller and frame. Pull web end to tighten. Three inches of web must extend past buckle.



Tongue Buckle: Pass webbing through buckle and insert tongue through grommet.

4.0 TRAINING

- 4.1 It is the responsibility of the user to assure they are familiar with these instructions, and are trained in the correct care and use of this equipment. User must also be aware of the operating characteristics, application limits, and the consequences of improper use of this equipment.

WARNING: Training must be conducted without exposing the trainee to a fall hazard. Training should be repeated on a periodic basis.

5.0 INSPECTION

5.1 FREQUENCY:

- **Before Each Use** inspect according to steps listed in section 5.2.
- **This Equipment** must be inspected according to steps listed in section 5.2 by a competent person, other than the user, at least annually. Record the results of each inspection in the "Inspection and Maintenance Log".

IMPORTANT: Extreme working conditions (harsh environments, prolonged use, etc.) may require increasing the frequency of inspections.

5.2 INSPECTION STEPS:

- Step 1.** Inspect hardware (D-rings, buckles, tool snaps, etc.). These items must not be damaged, broken or distorted. These items must be free of sharp edges, burrs, cracks, worn parts, or corrosion. Hook gates must move freely and lock upon closing.
- Step 2.** Inspect webbing for concentrated wear. Material must be free of frayed strands, broken yarns, cuts, abrasions, burns, and discoloration. The webbing must be free of excessive soiling, paint build-up, and rust staining. Check for chemical or heat damage; indicated by brown, discolored, or brittle areas. Check for ultraviolet damage; indicated by discoloration and splinters and slivers along the webbing surface. All of the above factors are known to reduce strength. Damaged or questionable webbing should be removed from use.
- Step 3.** Inspect the wooden seat of the chair for cracks, especially near the webbing holes. Also check for rough edges or gouges that could result in slivers.
- Step 4.** Inspect labels. All labels must be present and fully legible. See "Labeling".
- Step 5.** Inspect each system component or subsystem according to manufacturer's instructions.
- Step 6.** Record the inspection date and results in the "Inspection and Maintenance Log".
- 5.3 If inspection reveals an unsafe or defective condition, remove the equipment from service and destroy, or contact an authorized service center for repair.

6.0 MAINTENANCE, SERVICING, STORAGE

- 6.1 Clean the webbing with water and a mild detergent. Wipe hardware dry with a clean, dry cloth and hang to air dry. Do not force dry with heat. An excessive build-up of dirt, paint, etc. may in severe cases, weaken the webbing.
- 6.2 Additional maintenance and servicing procedures must be completed by an authorized service center. Authorization must be in writing. Do not disassemble this equipment.
- 6.3 Store the chair or sling in a cool, dry, clean environment, out of direct sunlight. Avoid areas where chemical vapors may be present. Thoroughly inspect the equipment after extended storage.

7.0 SPECIFICATIONS

7.1 MATERIALS SPECIFICATIONS:

BOATSWAIN'S CHAIRS:

Model no. 1001140, 1001134, 1001170, 1001180, 1001190, 1001378

D-ring: Drop forged, alloy steel 5,000 lbs. tensile strength.

Webbing: Polyester

wooden seat: 1 in., 15 ply plywood

Thread: Polyester, size 346 and nylon, size 69

WORK SEATS:

Model no. 1001150

V-ring: Drop forged, alloy steel 4,000 lbs. tensile strength.

Webbing: Polyester

wooden seat: 3/4 in., 13 ply plywood

Model no. 1001004

D-ring: Drop forged, alloy steel 5,000 lbs. tensile strength.

Webbing: Polyester

wooden seat: 3/4 in., 13 ply plywood

Thread: Polyester, size 346 and nylon, size 69

Model no. 1001044

D-ring: Drop forged, alloy steel 5,000 lbs. tensile strength.

Webbing: Polyester

Thread: Polyester, size 346 and nylon, size 69

SEAT SLINGS:

Model no. 1001120, 1001090

D-ring: Drop forged, alloy steel 5,000 lbs. tensile strength.

Webbing: Polyester

Thread: Polyester, size 346 and nylon, size 69

Thread: Polyester, size 346 and nylon, size 69

8.0 TERMINOLOGY

AUTHORIZED PERSON: A person assigned by the employer to perform duties at a location where the person will be exposed to a fall hazard (otherwise referred to as "user" for the purpose of these instructions).

RESCUER: Person or persons other than the rescue subject acting to perform an assisted rescue by operation of a rescue system.

CERTIFIED ANCHORAGE: An anchorage for fall arrest, positioning, restraint, or rescue systems that a qualified person certifies to be capable of supporting the potential fall forces that could be encountered during a fall or that meet the criteria for a certified anchorage prescribed in this standard.

QUALIFIED PERSON: A person with a recognized degree or professional certificate and with extensive knowledge, training, and experience in the fall protection and rescue field who is capable of designing, analyzing, evaluating and specifying fall protection and rescue systems to the extent required by this standard.

9.0 LABELING

9.1 THE FOLLOWING LABELS MUST BE PRESENT AND FULLY LEGIBLE:

ALL BOATSWAIN'S CHAIRS, SLING SEATS, AND TREE TRIMMER BELTS IN THIS MANUAL ARE REQUIRED TO HAVE THE FOLLOWING TWO LABELS:

9503717 REV K	SERIAL NO. NUMERO DE SERIE XXXXXX INSPECTION LOG RELEVÉ D'INSPECTION DATE INITIAL/INITIALE	<table border="1"> <tr><td> </td><td> </td><td> </td><td> </td><td> </td><td> </td><td> </td><td> </td><td> </td><td> </td></tr> <tr><td> </td><td> </td><td> </td><td> </td><td> </td><td> </td><td> </td><td> </td><td> </td><td> </td></tr> </table>																					DO NOT REMOVE THIS LABEL NE PAS ENLEVER CETTE ÉTIQUETTE

Inspection Log Label

9501134 REV T	▲ WARNING MANUFACTURER'S INSTRUCTIONS SUPPLIED WITH THIS PRODUCT AT TIME OF SHIPMENT MUST BE FOLLOWED. FAILURE TO DO SO COULD RESULT IN SERIOUS INJURY OR DEATH. CONTACT DBI-SALA IF INSTRUCTION SHEET IS NEEDED. INSPECT BEFORE EACH USE; IF WEAR OR DAMAGE EXIST, DO NOT USE. THIS SUSPENSION BELT IS INTENDED TO BE USED AS AN INDEPENDENT WORK SUPPORT, TO SUSPEND OR SUPPORT THE WORKER (FEDERAL LAW REQUIRES USE OF A BACKUP FALL PROTECTION SYSTEM WITH SUSPENSION SEATS). ITEMS SUBJECT TO IMPACT FORCES MUST BE IMMEDIATELY REMOVED FROM SERVICE AND DESTROYED. CONNECTING SNAP AND D-RING MUST BE COMPATIBLE IN SIZE, SHAPE AND STRENGTH. THIS ITEM IS NOT FLAME OR HEAT RESISTANT. REPAIRS ONLY TO BE PERFORMED BY DBI-SALA. EQUIPMENT MODIFICATIONS OR MISUSE VOIDS WARRANTY.	 www.capitalsafety.com MFRD (YR/MO)/LOT: MODEL NO: SIZE:	SUSPENSION BELT MEETS OSHA REQUIREMENTS POLYESTER WEB CONSTRUCTION DO NOT REMOVE LABEL
---------------	---	--	---

Suspension Belt Identification Label

BOATSWAIN'S CHAIR MODEL NUMBER 1001134 IS REQUIRED TO HAVE THE FOLLOWING LABEL IN ADDITION TO THE LABELS ABOVE.

 www.capitalsafety.com +1-800-328-6146	▲ WARNING MANUFACTURER'S INSTRUCTIONS MUST BE READ AND UNDERSTOOD PRIOR TO USE. INSTRUCTIONS SUPPLIED WITH THIS PRODUCT AT TIME OF SHIPMENT MUST BE FOLLOWED. FAILURE TO DO SO COULD RESULT IN SERIOUS INJURY OR DEATH. INSPECT BEFORE EACH USE. IF WEAR OR DAMAGE EXIST, DO NOT USE. THIS BODY BELT IS INTENDED TO BE USED TO RESTRAIN A WORKER FROM REACHING A HAZARD OR TO PROVIDE WORK SUPPORT ONCE THE USER REACHES A WORK POSITION. DO NOT USE FOR FALL ARREST. ITEMS SUBJECT TO IMPACT LOADING MUST BE IMMEDIATELY REMOVED FROM SERVICE AND DESTROYED. MAKE ONLY COMPATIBLE CONNECTIONS. THIS ITEM IS NOT FLAME OR HEAT RESISTANT. REPAIRS OF THIS PRODUCT MAY ONLY BE PERFORMED BY DBI. EQUIPMENT MODIFICATION OR MISUSE VOIDS WARRANTY. DO NOT REMOVE THIS LABEL.	BODY BELT POLYESTER WEB PRODUCT COMPLIANCE THIS PRODUCT COMPLIES WITH THE FOLLOWING STANDARDS ONLY IF MARKED WITH THE CORRESPONDING LETTER CODE UNDER "STDS" SECTION BELOW. A = ANSI Z359.1 B = OSHA C = ANSI A10.32-2004 D = ASTM F287-2004 E = MFRD (YR/MO): LOT: MODEL NO: SIZE: STDS:
---	--	---

9501151 REV Z

Body Belt Identification Label

This instruction applies to the following Models:

1001001	1001015	1001032	1001046	1001063	1001110	1001140	1001272	1001378
1001002	1001016	1001033	1001047	1001064	1001120	1001150	1001273	1003225
1001003	1001017	1001034	1001053	1001065	1001125	1001155	1001274	1003226
1001004	1001019	1001035	1001054	1001070	1001131	1001170	1001275	8900001
1001005	1001020	1001037	1001055	1001071	1001132	1001180	1001276	
1001006	1001021	1001041	1001056	1001080	1001133	1001185	1001280	
1001007	1001022	1001042	1001057	1001081	1001134	1001190	1001281	
1001012	1001023	1001043	1001060	1001082	1001135	1001200	1001282	
1001013	1001024	1001044	1001061	1001090	1001136	1001270	1001283	
1001014	1001031	1001045	1001062	1001100	1001137	1001271	1001284	

Additional Model Numbers may appear on the next printing of these instructions.

LIMITED LIFETIME WARRANTY

Warranty to End User: D B Industries, Inc., dba CAPITAL SAFETY USA ("CAPITAL SAFETY") warrants to the original end user ("End User") that its products are free from defects in materials and workmanship under normal use and service. This warranty extends for the lifetime of the product from the date the product is purchased by the End User, in new and unused condition, from a CAPITAL SAFETY authorized distributor. CAPITAL SAFETY'S entire liability to End User and End User's exclusive remedy under this warranty is limited to the repair or replacement in kind of any defective product within its lifetime (as CAPITAL SAFETY in its sole discretion determines and deems appropriate). No oral or written information or advice given by CAPITAL SAFETY, its distributors, directors, officers, agents or employees shall create any different or additional warranties or in any way increase the scope of this warranty. CAPITAL SAFETY will not accept liability for defects that are the result of product abuse, misuse, alteration or modification, or for defects that are due to a failure to install, maintain, or use the product in accordance with the manufacturer's instructions.

CAPITAL SAFETY'S WARRANTY APPLIES ONLY TO THE END USER. THIS WARRANTY IS THE ONLY WARRANTY APPLICABLE TO OUR PRODUCTS AND IS IN LIEU OF ALL OTHER WARRANTIES AND LIABILITIES, EXPRESSED OR IMPLIED. CAPITAL SAFETY EXPRESSLY EXCLUDES AND DISCLAIMS ANY IMPLIED WARRANTIES OF MERCHANTABILITY OR FITNESS FOR A PARTICULAR PURPOSE, AND SHALL NOT BE LIABLE FOR INCIDENTAL, PUNITIVE OR CONSEQUENTIAL DAMAGES OF ANY NATURE, INCLUDING WITHOUT LIMITATION, LOST PROFITS, REVENUES, OR PRODUCTIVITY, OR FOR BODILY INJURY OR DEATH OR LOSS OR DAMAGE TO PROPERTY, UNDER ANY THEORY OF LIABILITY, INCLUDING WITHOUT LIMITATION, CONTRACT, WARRANTY, STRICT LIABILITY, TORT (INCLUDING NEGLIGENCE) OR OTHER LEGAL OR EQUITABLE THEORY.



A Capital Safety Company

CSG USA & Latin America

3833 SALA Way
Red Wing, MN 55066-5005
Toll Free: 800.328.6146
Phone: 651.388.8282
Fax: 651.388.5065
solutions@capitalsafety.com

CSG Canada

260 Export Boulevard
Mississauga, ON L5S 1Y9
Phone: 905.795.9333
Toll-Free: 800.387.7484
Fax: 888.387.7484
info.ca@capitalsafety.com

CSG Northern Europe

Unit 7 Christleton Court
Manor Park
Runcorn
Cheshire, WA7 1ST
Phone: + 44 (0)1928 571324
Fax: + 44 (0)1928 571325
csgne@capitalsafety.com

CSG EMEA (Europe, Middle East, Africa)

Le Broc Center
Z.I. 1ère Avenue
5600 M B.P. 15 06511
Carros
Le Broc Cedex
France
Phone: + 33 4 97 10 00 10
Fax: + 33 4 93 08 79 70
information@capitalsafety.com

CSG Australia & New Zealand

95 Derby Street
Silverwater
Sydney NSW 2128
AUSTRALIA
Phone: +(61) 2 8753 7600
Toll-Free : 1 800 245 002 (AUS)
Toll-Free : 0800 212 505 (NZ)
Fax: +(61) 2 87853 7603
sales@capitalsafety.com.au

CSG Asia

Singapore:
16S, Enterprise Road
Singapore 627666
Phone: +65 - 65587758
Fax: +65 - 65587058
inquiry@capitalsafety.com

Shanghai:

Rm 1406, China Venturetech Plaza
819 Nan Jing Xi Rd,
Shanghai 200041, P R China
Phone: +86 21 62539050
Fax: +86 21 62539060

www.capitalsafety.com



Certificate No. FM 39709