

Installation Sheet 5903448 - Wire Rope Loop Termination

Materials:

- ❑ 3/16 in Galvanized Wire Rope Cable - P/N 6160028 or equivalent (must be approved by Capital Safety)
- ❑ Wire Rope U-Loop Splice Compression Connector - P/N 9506922

Tools:

- ❑ Swage Die Set - P/N 9600003
- ❑ Compression Tool, 12 Ton, 1 inch Jaw - P/N 9600069 or equivalent that handles "U" Type Dies
- ❑ 28 inch Type ACSR Wire Rope & Cable Cutter, 1 inch Cable Diameter - P/N 9600068 or equivalent
- ❑ Permanent Marker

WARNING: Termination of the Wire Rope Ends requires careful attention to detail. Improper termination can result in serious injury or death.

1. Install Die Halves in the Compression Tool per the manufacturer's operating instructions. Make sure Die Halves are oriented in the Compression Tool Jaws so the impressions in the Die Halves are symmetrical with each other.
2. Carefully inspect the Compression Sleeve for defects. Ensure that the Wire Rope End will seat properly in the Compression Sleeve.
3. Carefully insert the Wire Rope End through the Compression Sleeve until the end aligns with the top of the flange on the Compression Sleeve. Mark the Wire Rope with a Permanent Marker where it exits the Compression Sleeve.



IMPORTANT: Do not allow the Wire Rope strands to unravel or bend out of place.

WARNING: The Wire Rope must be fully inserted to achieve the strongest possible connection. Improper installation can result in serious injury or death.

4. Position the Connector in one Die Half so Compression Sleeve rests entirely in the impression in the Die Half with the flange on the Compression Sleeve aligned in the horizontal groove in the Die Half. The empty Compression Sleeve should align in the recess in the end of the Die Half.
5. Crimp the Compression Sleeve onto the Wire Rope End per the manufacturer's instructions provided with the Compression Tool. **Fully crimp each Compression Sleeve four times**, rotating it 90 degrees between crimps. The fourth and final crimp should apply pressure directly on the Compression Sleeves two Wire Loops.

After crimping, inspect the mark made in Step 3 to verify that the Wire Rope did not slip out of the Compression Sleeve during crimping.

IMPORTANT: To ensure proper compression, one person should hold the Wire Rope in place while a second person operates the Compression Tool. Keep fingers clear of the Die Halves during crimping.

6. Repeat Steps 2 through 5 on the other end of the Wire Rope and remaining Compression Sleeve to complete the Wire Rope splice.

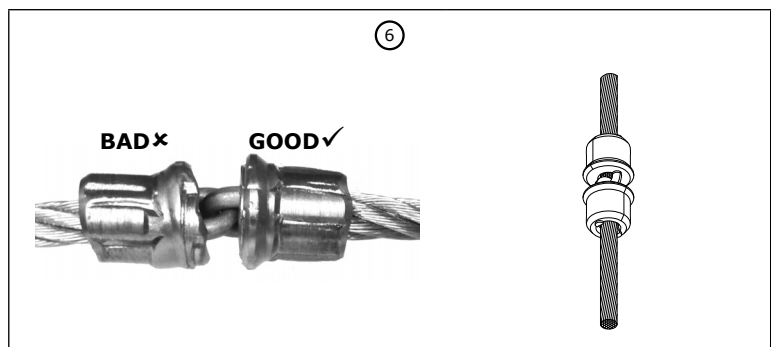
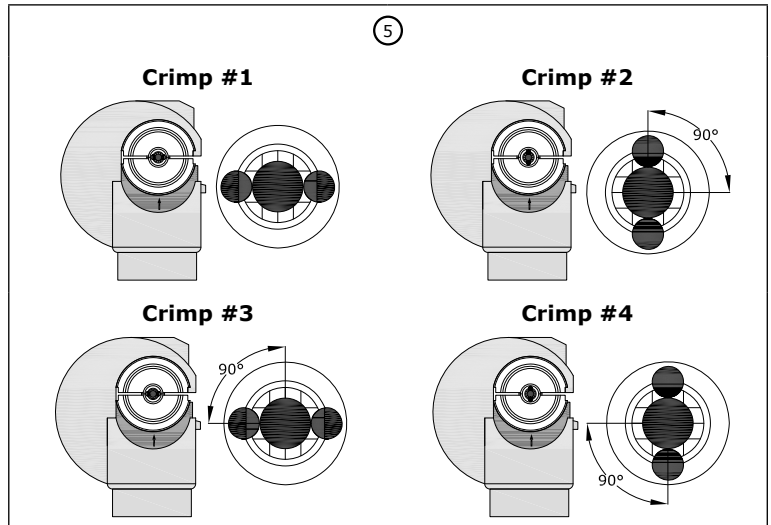
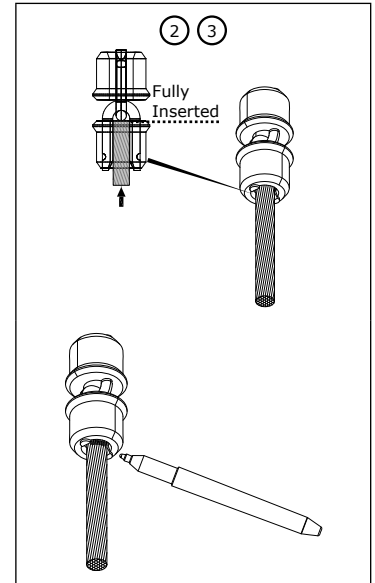
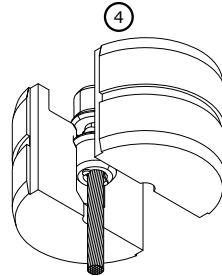
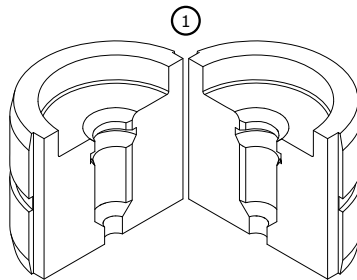



Global Leader in Fall Protection

USA

3833 SALA Way
Red Wing, MN 55066-5005
Toll Free: 800.328.6146
Phone: 651.388.8282
Fax: 651.388.5065
solutions@capitalsafety.com

Brazil

Rua Anne Frank, 2621
Boqueirão Curitiba PR
81650-020
Brazil
Phone: 0800-942-2300
brasil@capitalsafety.com

Mexico

Calle Norte 35, 895-E
Col. Industrial Vallejo
C.P. 02300 Azcapotzalco
Mexico D.F.
Phone: (55) 57194820
mexico@capitalsafety.com

Colombia

Compañía Latinoamericana de Seguridad S.A.S.
Carrera 106 #15-25 Interior 105 Manzana 15
Zona Franca - Bogotá, Colombia
Phone: 57 1 6014777
servicioalcliente@capitalsafety.com

Canada

260 Export Boulevard
Mississauga, ON L5S 1Y9
Phone: 905.795.9333
Toll-Free: 800.387.7484
Fax: 888.387.7484
info.ca@capitalsafety.com

EMEA (Europe, Middle East, Africa)

EMEA Headquarters:
5a Merse Road
North Moons Moat
Redditch, Worcestershire
B98 9HL UK
Phone: + 44 (0)1527 548 000
Fax: + 44 (0)1527 591 000
csgne@capitalsafety.com

France:

Le Broc Center
Z.I. 1re Avenue - BP15
06511 Carros Le Broc Cedex
France
Phone: + 33 04 97 10 00 10
Fax: + 33 04 93 08 79 70
information@capitalsafety.com

Australia & New Zealand

95 Derby Street
Silverwater
Sydney NSW 2128
Australia
Phone: +(61) 2 8753 7600
Toll-Free : 1800 245 002 (AUS)
Toll-Free : 0800 212 505 (NZ)
Fax: +(61) 2 8753 7603
sales@capitalsafety.com.au

Asia

Singapore:

69, Ubi Road 1, #05-20
Oxley Bizhub
Singapore 408731
Phone: +65 - 65587758
Fax: +65 - 65587058
inquiry@capitalsafety.com

Shanghai:

Rm 1406, China Venturetech Plaza
819 Nan Jing Xi Rd,
Shanghai 200041, P R China
Phone: +86 21 62539050
Fax: +86 21 62539060
inquiry@capitalsafety.cn

www.capitalsafety.com

